

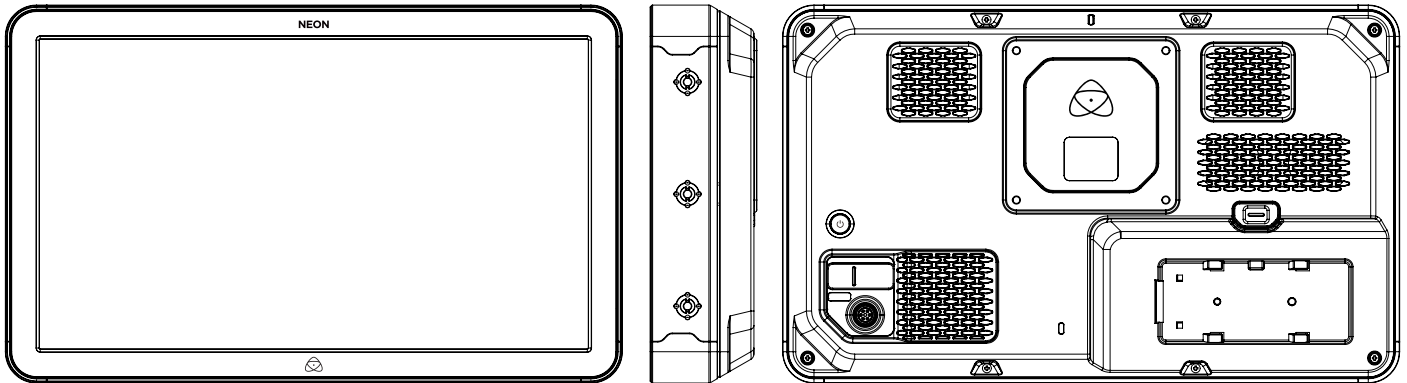

# NEON 17

## Atomos NEON 17" HD HDR Production Monitor



### Key Features

- 17" 16:9 FHD 1920 x 1080 display with DCI P3 wide gamut and 1,000,000:1 Dynamic contrast ratio
- 1000nits HDR with Dynamic Full Array Local Dimming to achieve full panel uniformity and deep blacks
- AtomHDR Display color pipeline management for LOG to PQ (HDR10), HLG with 3DLut for SDR workflows
- Support up to 4k60p via HDMI 2.0 or 12G SDI with 10-bit signal Loop outs
- Anti-glare screen coating and a wide viewing angle
- HD and 4k image processing and the output with DCI Crop or Down convert to HD
- AtomRemote OS provides control of all NEON function from iOS via Bluetooth (iOS Device **REQUIRED** for operation of NEON.)
- Factory calibrated with option for simple Automated Calibration Application with support for Xrite iDisplay Pro Plus

### Providing Certainty of image for the entire crew

NEON 17 is a precision on-set and in-studio HD HDR production monitor-recorder featuring 1000nits fullscreen brightness, 0nits deep black and wide colour gamut accuracy.

### Record

Connect cameras or any video source via SDI supporting up to 4K DCI 60p via 12G or Dual 6G or lower resolutions and frame rates via 1.5/3G SDI with up to 12 channels of embedded audio. HDMI 2.0 provides support for 4K up to 60p and HD up to 120p. Recordings are captured to industry standard Apple ProRes or Avid DNx Codec with rich metadata in the file header that can be utilized by your NLE or MAM system to asset orchestration.

### Flexible and Upgradeable I/O

The NEON series adopts a modular approach that ensures the I/O of the monitor is easy to maintain, replace and ultimately upgrade without having to decommission the panel. The Master Control Unit (MCU) is the brain of the NEON, with built in HDMI 2.0 and audio mini jack I/O. The MCU's AtomX Expansion Port allows for upgrade to the connections, including the AtomX SDI Module which provides 2 x 12G SDI that can be used for dual link or separate inputs or outputs. As standards and interfaces develop, both the MCU and Xpansion port modules can be changed and upgraded to meet your needs without needing to change the entire monitor.

### AtomOS enhanced playback

NEON includes essential monitoring tools from slow motion playback, frame-by-frame analysis and preview tools including full scopes, zebra, false color, focus peaking, exposure and LUTs.

### Monitor

Selectable monitor modes allow you work in either SDR or HDR with settings that match both camera acquisition settings or defined delivery standards including Rec.709, Rec.2100 HLG or ST.2084 PQ. NEON provides reliable color reproduction with DCI-P3 coverage, wide color gamuts such as BT.2020 can be processed accurately. Downstream outputs option also provides for conversion between standards to best suit the target display with options for LOG put to HDR.

### Frame Guides, Safe Areas & more

A variety of broadcast frame guides are available with the option for Graphic and Action safe areas. Cinematic guides are also available, with additional anamorphic de-squeeze mode with support for 2x, 1.5x and 1.33x to allow you to match a wide variety of lenses.

### App control for simple operation

Connect your NEON over Bluetooth to the Atomos remote app. Note: Apple iOS Device **REQUIRED** for operation of NEON.

### Price

US\$3999 ex. tax | €3699 ex. tax

# NEON 17 - Technical specifications

## Physical Specifications

Weight (monitor only)	4.5kg / 9.92lb
Dimensions (Control Unit)	413 x 253 x 71.4mm
Mount Points	Full ARRI compatible, 3 Left, 3 Right, 7 Top, 7 Bottom. Rear 100 x 100 VESA Mount
Feet	2 x Feet with 1/4" 20 with anti rotation pins
Security leash point	Kensington lock on rear and lock down point on feet
Rack mount	Via 3rd party shell/d with Vesa mount

## Construction

Body	Aluminium alloy chassis with ABS Polycarbonate back plate
Cooling	Active
Tally light	Rear
Function Button	Power button to lock screen and pair remote control devices

## Power

Operating Power	19v 180Watts
DC in	Multi pin input on rear

## Display

Touchscreen	Yes, Dynamic
Size	16.5"
Resolution	FHD 1920x1080 - 16:9
Viewing Angle	180 degrees Horizontal & Vertical (+/- 10%)
PPI	142
Bit Depth	10-bit (8+2 FRC)
Backlight	Dynamic Full Array Local Dimming (FALD) 128 Zones
Brightness	1000nits Full Screen brightness * (+/- 10%)
Black Level	Onits
LED	Wide Color Calibrated D65
Contrast Ratio	Dynamic 1,000,000 : 1
Aspect Ratio	16:9
Color Gamut	DCI P3

## Technology

AtomHDR Technology	Yes
3D LUT Support	Display only
HDR Monitoring Technology	HLG, PQ, Camera LOG
HDR Output Conversion	Log/HDR to HLG/ PQ
Gamma	Sony SLog / SLog2 / SLog3, Canon CLog / CLog2 / Clog3, ARRI Log CEI160 / LogCEI200 / LogCEI250 LogCEI320 / LogCEI400 / LogCEI500 / LogCEI640 / LogCEI800 / LogCEI1000 / LogCEI1280 / LogCEI1600, Panasonic Vlog JVC JLog1, / Log3G12, RED Log3G10 / RED LogFilm, FujiFilm F-log, Nikon N-Log PQ (HDR10), HLG
Gamut	Sony SGamut / SGamut3 / SGamut3.cine, Canon Cinema / DCI P3 / DCI P3+ Panasonic V Gamut, Arri Alexa Wide Gamut, Rec709, Bt2020, DCI P3, DCI p3 65 JVC LS300, Red DragonColor / DragonColor2 / RedColor2 / RedColor3 / RedColor4 / RedWideGamut

## Module System

Master Control Unit (MCU)	Yes
AtomXpansion Slot	Yes, Support for SDI and future modules

## Video Input

HDMI	1 x HDMI (2.0) 4k p60
SDI	2 x 12G SDI via included AtomX SDI module
Signal (camera dependent)	Uncompressed true 10-bit or 8-bit 422
LTC (Record Mode Only)	Wireless RF SYNC - Future FW Release
Video Preview Monitoring - HDR	For accurate full 10bit baseband video monitoring a 3rd party PCIe or Thunderbolt video I/O device with HDMI or SDI is required

## Video Output

HDMI	1 x HDMI (2.0)
SDI	1 x 12G SDI on Loop out from SDI, 2 x 12G SDI on playback via included AtomX SDI module
Signal	Uncompressed true 10-bit or 8-bit 422 (playback file dependent)

## Audio In/Out

Audio Quality	24/48kHz
Audio Codec	Linear PCM
HDMI	8ch 24-bit, input dependent
SDI	12ch 24-bit, input dependent
Analogue Audio in	3.5mm 2ch.
Headphone out	3.5mm 2ch.
Audio Out	Selected embedded stereo pair via 3.5mm headphone jack

## Supported Codex & Frame Rates (Record & Playback)

Supported resolution & FPS	4k DCI: 23.98/24/25/29.9/30/50/59.94/60p 4k UHD: 23.98/24/25/29.9/30/50/59.94/60p 2k DCI: 23.98/24/25/29.9/30/50/59.94/60p via SDI only 1080i: - 50/59.94i 720p: 50/59.94/60p
CDNG	-
Apple ProRes Raw	-
Apple ProRes	LT, 422, HQ
Avid DNx	DNxHR HQX, HQ, SQ, LB, DNxHD 220x, 220, 145, 36

## Playback

Loop	Yes - full video file only
Apple ProRes	Yes - Recorded on Device or Exported from NLE (in .MOV with inear PCM audio)
Avid DNx	Yes - Recorded on Device or Exported from NLE (in .MOV with inear PCM audio)

## Recording functions & Media

Pre-roll record	Yes (HD 8s, 4K 2s)
Supported media	2.5" SSD/HDD compatibility depends on recording format, resolution and frame rate. Visit atomos.com/ drives for list of tested and approved drives
Media support	Master Caddy II / SSDmini
File Naming	Scene / Shot / Take , RED / Arri Via SDI
Supported Editing applications	All application supporting Apple ProRes / Avid DNx in .MOV wrapper

## On Screen Tools

Waveform	Yes
RGB Parade	Yes
Vector Scope	Yes
1 x Zoom	Yes
2 x Zoom	Yes
Focus Peaking	Color selected / color / Mono / edges only
False Color	Yes
Zebra	Yes
Isolate Color Channe	Blue Only
Cine Frame Guides	2.4:1, 2.35:1, 1.9:1, 1.85:1, 4:3
Safe Areas	Yes
Anamorphic Desqueeze	1.33x , 1.5x ,2x

## Timecode

HDMI	Yes
SDI	Yes
Time Of Day	Yes
Wireless RF	Future FW Release

## Onboard Processing

Pulldown removal	24/25/30pSF > 24/25/30p (2:2 pulldown) 60i > 24p (3:2 pulldown)
Deinterlace mode	Yes
4K UHD downscale for HD on output	Yes
DCI crop on output	Yes

## Remote control

HDMI	Auto HDMI Trigger Supported Protocols - Canon, Sony, Atomos Open Standard
SDI	SDI trigger camera selectable
LANC 2.5mm Jack	LANC control - Calibration on MCU
LE Bluetooth	Apple iOS 12 and above

## What's in the box

Accessories included	NEON 17 Monitor, NEON Master Control Unit, 2 x Feet (inc. mount screws x 2), NEON Quick Start Guide  1 x Master Caddy II (inc. screws), 19V AC Power Adapter with mount cage, AtomX SDI Expansion Module  Monitor Protective Sheath, MCU Protective Sheath, Hex Wrench.
Optional extras	Atomos NEON 17" Case, Xrite iDisplay, Atomos USB A to Serial Calibration cable, AtomX USB-C Caddy

## Warranty

Standard	1 year. Extended to 3 yrs on product registration
----------	---

**Please note:** Specifications are subject to change without notice. All information correct at time of publishing.

\*In ambient temperatures of < 25° C